

1. Place frame on floor with light brackets on top and lights (optional) facing forward.
2. Grasp the top of the frame with both hands and extend framework until you are able to reach the two middle center hubs. Push them towards each other until framework is extended to full height (do not lift frame by lighting). Snap the 2 aluminum connectors together (detail 1).
3. Unfold the mag bars, and slide hinged sections together. Repeat for both hinge locations (hinges fold in opposite directions). Install magbar top into recessed bottom of light bracket (detail 2) with magnets facing out, then "snap" the rear opening of the magbar at the hinge onto each stud projecting from the units hubs. Repeat this action for all front hubs and the left and right side rear hubs.
4. Remove fabric/graphic panels from case and locate hooks on upper corners. Hang hooks on the frame over the silver metal rivets on the light brackets (detail 3). Hang the panels on the rivets starting with one of the main panels.
5. Hang the two end panels the same way; one side attaches to a hanging metal rivet on the front side of the display, and the other side attaches to the back metal hanging rivet to form the curve.

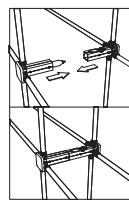

Detail 1

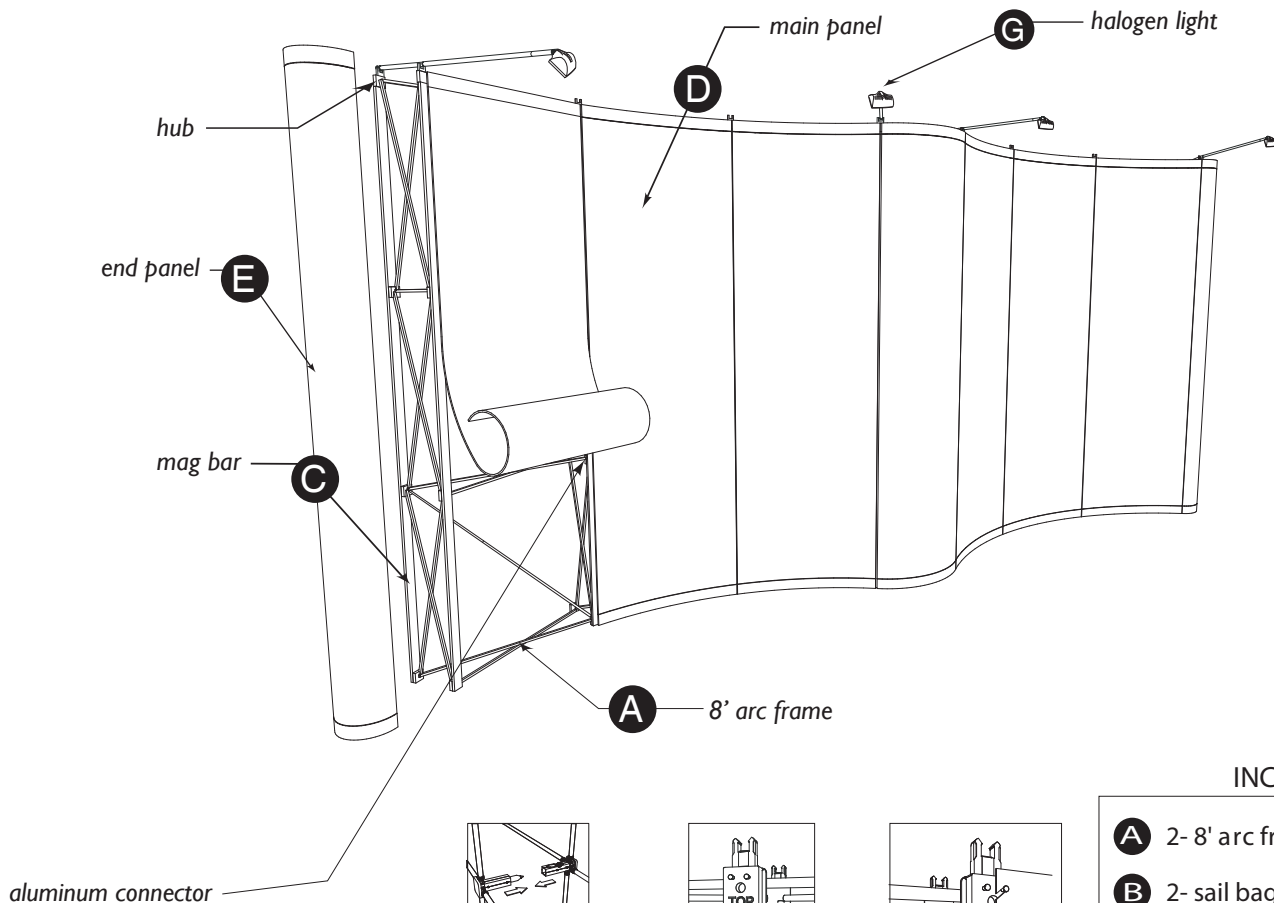
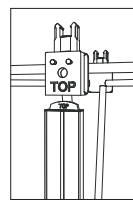

Detail 2

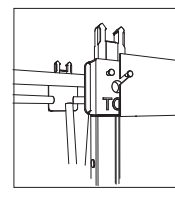

Detail 3

INCLUDES

- A** 2- 8' arc frames with feet
- B** 2- sail bags
- C** 12- mag bars
- D** 8- main panels
- E** 4- 1 piece end panels
- F** 2 or 4 cases (2 large, 4 small cases)
- G** 4- halogen lights (optional)